

# **BizCardReader 6.3**

**Windows XP / Vista**

## **Quick Start**

Guide to installation and getting started

**CardReader, Inc.**

[www.bizcardreader.com](http://www.bizcardreader.com)

### **Copyright Notice**

CardReader, Inc., 1994 - 2009. All rights reserved. No part of this book may be reproduced or copied in any form or by any means - graphic, electronic, or mechanical, including photocopying, recording, taping, or information and retrieval systems - without written permission of the publisher.

**CardReader, Inc.**  
California, USA  
**[www.bizcardreader.com](http://www.bizcardreader.com)**

## **END USER SOFTWARE LICENSE AGREEMENT FOR BIZCARDREADER**

### **IMPORTANT**

READ CAREFULLY THIS LICENSE AGREEMENT. BY INSTALLING, COPYING OR OTHERWISE USING THIS SOFTWARE, YOU ACCEPT ALL THE TERMS AND CONDITIONS OF THIS AGREEMENT. IF YOU DO NOT ACCEPT THE TERMS OF THIS AGREEMENT, DO NOT INSTALL, COPY, OR USE THE SOFTWARE

### **DEFINITION**

"SOFTWARE" refers to the computer program contained in this package. The term also includes all copies of any part of the computer program.

### **COPYRIGHT PROTECTION**

This SOFTWARE is owned by CardReader, Inc. ("CRI") or its suppliers and is protected by United States and international copyright laws and international trade provisions. Therefore you must treat this SOFTWARE like any copyrighted material except that you may either (a) make one copy of the SOFTWARE solely for backup or archival purposes, or (b) transfer the SOFTWARE to a single hard-disk and retain the original solely for backup or archival purposes. You may not copy any written materials accompanying the SOFTWARE.

### **LICENSE GRANT**

You may install and use the SOFTWARE on a single computer or on a network server provided that you acquire and dedicate a license for each computer that will be used to operate the SOFTWARE. A license for the SOFTWARE may not be shared or used concurrently on different computers. You may increase the total number of licenses you own by adding together individual licenses for the SOFTWARE.

You may not rent or lease the SOFTWARE, but you may transfer the SOFTWARE and all accompanying written materials on a permanent basis to another person or entity provided that you retain no copies and the recipient agrees to the terms of this agreement.

You may not reverse engineer, decompile, disassemble, or create derivative works from the SOFTWARE.

### **UPGRADES**

If the SOFTWARE is an upgrade, you may use or transfer the SOFTWARE only in conjunction with the upgraded product, unless you destroy the upgraded product. Any transfer must include all prior versions of the SOFTWARE and documentation.

### **TERMINATION**

This license will terminate automatically if you fail to comply with any of the terms or conditions of this Agreement. On termination, you must destroy all copies of the SOFTWARE and documentation.

### **LIMITED WARRANTY**

CRI warrants that the SOFTWARE will perform substantially in accordance with the accompanying written materials for a period of 60 days from the date of receipt.

If the SOFTWARE fails to comply with the warranty set forth above, CRI's entire liability and your exclusive remedy will be, at CRI's option, either (a) the refund of purchase price, or (b) the replacement of the SOFTWARE. Any replacement SOFTWARE will be warranted for the remainder of the original 60-day warranty period or for 30 days from the date you received the replacement, whichever is longer.

THE ABOVE WARRANTIES ARE EXCLUSIVE AND IN LIEU OF ALL OTHER WARRANTIES, EXPRESSED OR IMPLIED, INCLUDING BUT NOT LIMITED TO THE IMPLIED WARRANTIES OF MERCHANTABILITY, FITNESS FOR A PARTICULAR PURPOSE AND NONINFRINGEMENT. NO ORAL OR WRITTEN INFORMATION OR ADVICE GIVEN BY CRI, OR ITS EMPLOYEES, DISTRIBUTORS, AGENTS, OR DEALERS SHALL INCREASE THE SCOPE OF THE ABOVE WARRANTIES OR CREATE ANY NEW WARRANTIES.

THIS WARRANTY GIVES YOU SPECIFIC LEGAL RIGHTS, AND YOU MAY HAVE OTHER LEGAL RIGHTS THAT MAY VARY FROM STATE TO STATE.

**LIMITATION OF LIABILITY**

CRI SHALL NOT BE LIABLE FOR ANY DAMAGES WHATSOEVER (INCLUDING, WITHOUT LIMITATION TO, DAMAGES FOR LOSS OF PROFITS, BUSINESS INTERRUPTION, LOSS OF INFORMATION, OR OTHER PECUNIARY LOSS) ARISING OUT OF THE USE OR INABILITY TO USE THIS SOFTWARE. IN NO EVENT SHALL CRI'S LIABILITY FOR DAMAGES RELATED TO THE INSTALLATION OR USE OF THE SOFTWARE EXCEED THE AMOUNT YOU PAID FOR THE SOFTWARE.

SOME JURISDICTIONS DO NOT ALLOW EXCLUDING OR LIMITING IMPLIED WARRANTIES OR LIMITING LIABILITY FOR INCIDENTAL OR CONSEQUENTIAL DAMAGES, AND SOME JURISDICTIONS HAVE SPECIAL STATUTORY CONSUMER PROVISIONS WHICH MAY SUPERSEDE THIS LIMITATION. AS A RESULT, THIS LIMITATION OF LIABILITY MAY NOT APPLY TO YOU IF PROHIBITED BY THE LAWS OF YOUR JURISDICTION.

**US GOVERNMENT RESTRICTED RIGHTS**

The SOFTWARE and documentation are provided with restricted rights. Use, duplication or disclosure by the Government is subject to restrictions as set forth in subparagraph (c)(1)(ii) of the Rights in Technical Data and Computer Software clause at DFARS 252.227-7013 or subparagraphs (c)(1) and (2) of the Commercial Computer Software - Restricted Rights at 48 CFR 52.227-19, as applicable. Manufacturer is CardReader, Inc., 1411 Ramon Dr., Sunnyvale CA 94087.

**GENERAL**

This agreement will be governed by the laws of the state of California. This Agreement is deemed entered into at Sunnyvale, California by both parties. If any provision of this agreement is found to be unlawful, void, or unenforceable, then that provision shall be severed from this agreement and shall not affect the validity and enforceability of any of the remaining provisions.



# Contents

---

<b>CONTENTS .....</b>	<b>IV</b>
<b>GENERAL INFORMATION.....</b>	<b>1</b>
SYSTEM REQUIREMENTS .....	1
INSTALLING THE CARD SCANNER.....	1
THE DUPLEXSCAN 1200 CARD SCANNER.....	2
GETTING HELP ONLINE .....	2
<b>SYSTEM SETTINGS.....</b>	<b>3</b>
<b>SCANNER SETTINGS.....</b>	<b>3</b>
<b>GETTING STARTED.....</b>	<b>4</b>
SCANNING BUSINESS CARDS .....	4
SCANNING DOUBLE-SIDED CARDS.....	4
ATTACHING IMAGES .....	5
<b>TRANSFERRING DATA.....</b>	<b>6</b>
TRANSFER DATA TO MICROSOFT OUTLOOK .....	6
TRANSFER DATA TO LOTUS NOTES.....	6
TRANSFER DATA TO PALM PILOT .....	6
TRANSFERRING DATA TO OTHER APPLICATIONS .....	8
<b>THE MAIN WINDOW .....</b>	<b>9</b>
<b>CONTROL MENU AND IMAGE ICONS .....</b>	<b>11</b>
<i>Control Menu Icons</i> .....	11
<i>Control Menu Icons</i> .....	11
<b>VIEWING CARDS.....</b>	<b>12</b>
DISPLAY MODE .....	12
NOTES FIELD .....	12
VIEWING RECORDS.....	12
<b>VERIFYING CARD INFORMATION.....</b>	<b>12</b>
ZOOMING IN & OUT OF THE IMAGE .....	13
SHIFTING THE IMAGE WINDOW.....	13
ROTATING SCANNED IMAGE.....	13
READ CARD CONTENTS .....	13
<b>SEARCHING AND SORTING.....</b>	<b>13</b>
SEARCHING FOR A CARD.....	13
SORTING.....	13
<b>EDITING RECORDS .....</b>	<b>14</b>
EDITING TEXT .....	14

DRAG & DROP.....	14
<b>MANAGING DATABASES .....</b>	<b>14</b>
DATABASE FILES AND IMAGE FILES .....	14
OPENING A DATABASE.....	15
SAVING A DATABASE.....	15
COPYING A DATABASE .....	15
MERGING DATABASES .....	15
DELETING A DATABASE .....	15
COPY FIELD CONTENTS .....	16
UPDATING A DATABASE.....	16
<b>EXPORTING A DATABASE .....</b>	<b>16</b>
EXPORT METHODS .....	16
AUTOMATIC EXPORT.....	16
<b>PRINTING .....</b>	<b>17</b>
PRINTING LABELS.....	17
LABEL LAYOUT .....	17
PRINTING A REPORT .....	18
PRINT TO FILE .....	18
<b>SCANNER MAINTENANCE .....</b>	<b>19</b>
DUPLEXSCAN 1200 CLEANING PROCEDURE.....	19
BIZCARDREADER 900C CLEANING PROCEDURE.....	20
BIZCARDREADER 600C CLEANING PROCEDURE.....	20
BIZCARDREADER 300G CLEANING PROCEDURE.....	21
<b>SCANNER WARRANTY AND NOTICES .....</b>	<b>22</b>
LIMITED WARRANTY.....	22
FCC STATEMENT .....	22
DECLARATION OF CONFORMITY .....	22



# General Information

---

BizCardReader is an application that scans and manages your business cards by saving a picture of each card and automatically creating a database of your business contacts. Using Optical Character Recognition (OCR), a technology that allows computers to recognize printed text, BizCardReader will automatically read, sort and place card information into categories such as name, company and address in the database. BizCardReader also scans and stores color photographs.

## System Requirements

- PC compatible Intel Pentium system or higher
- Windows ME / 2000 / XP or higher
- Minimum 8 MB RAM
- Minimum 10 MB free hard disk space.
- Microsoft Windows compatible mouse.
- Available USB port with 0.5 A power (if card scanner is used)

## Installing the Card Scanner

The BizCardReader CD is needed to install the drivers for the card scanner.

You should logon to Windows as **Administrator** to ensure that you have sufficient privilege to install the scanner drivers.

### Installing the Scanner Driver

1. Insert the BizCardReader CD into the CD ROM drive and follow the on-screen instructions to install the BizCardReader application. Leave the CD in the drive and continue with the next step.
2. Plug the card scanner into the computer's USB port.
3. The system new hardware wizard will indicate that a new scanner has been found. Press "Next" to continue.
4. Select "**Search for the best driver (recommended) ...**" and click Next.
5. If prompted to specify a location for the scanner driver, select the **CD ROM drive** by checking the appropriate box.
6. Continue the installation procedure to completion.

### Troubleshooting the Card Scanner

#### (A) Improper driver installation

If the scanner will not scan after you install the driver, you should try to re-install/update the driver. The following procedure describes how this can be done.

1. Place the BizCardReader CD into the drive, and exit the application software installation if prompted.
2. Unplug the USB cable from the scanner for a few seconds and then plug it back in.
3. If the system new hardware wizard is displayed, then follow the steps described above to install the scanner driver. Otherwise go on to the next step.
4. Start up the Windows Control Panel by clicking on the Windows task bar Start... Control Panel.

5. In the Control Panel, select Performance/System and Maintenance and click on the System icon. Then select **Device Manager** (for Windows 2000/XP users click on **Hardware**, then **Device Manager**).
6. If you see the BizCardReader scanner device with an exclamation mark beside it, highlight it and click Properties/Update Driver. Follow the instructions to search/locate the driver on the CD ROM. Click Finish after the driver is installed.

### **(B) CONFLICT WITH OTHER USB DEVICES**

Some problems are due to conflicts with other devices on the USB. To resolve this, disconnect all other devices (and/or hubs), and plug the card scanner **directly** into the USB port of the computer. If necessary, re-install the scanner driver.

## **The DuplexScan 1200 Card Scanner**

The DuplexScan 1200 scanner is a double sided scanner which scans both sides of an input document in a single pass. The input document can be returned (ejected) either at the rear or the front of the scanner. The document eject mode is set from the software in the scanner settings and options.

### **Inserting the document (card) for scanning**

The card should be inserted into the front of the scanner at the RIGHT end of the input slot.

### **Battery Light**

The scanner contains a self-recharging battery that is automatically and continuously charged whenever the scanner is plugged into the live USB port of a computer. In normal operation, the Low Battery (red) light is usually off, but may turn on for a short duration of less than 10 seconds during scanning.

If the battery power is extremely low, the red light will remain on for several minutes. When this happens, leave the scanner plugged into a live USB port for several hours and the battery will be restored to normal. The battery should normally last for several years before it has to be replaced.

### **Optional External power adapter**

For high volume usage of more than 200 scans per hour, you can use an external power adapter to supplement the battery power. If this is needed, please contact CardReader, Inc. ([www.bizcardreader.com](http://www.bizcardreader.com)) to purchase the power adapter.

## **Getting Help Online**

The User's Guide for BizCardReader is available online. Simply start up BizCardReader and click on the Help item on the top menu bar. Click on the Contents tab and you will see the list of books and topics that will guide you through using all the features of the system.

In addition to selecting Help from the main menu, you can also access the Online Help from most dialog boxes by clicking on the Help buttons displayed in them.

For technical support visit [www.bizcardreader.com](http://www.bizcardreader.com)

# System Settings

---

In BizCardReader there are several settings that affect how the system processes the cards. To view the default system settings, select the **Settings** menu item. Then select the **System** option. The System Setting dialog box appears. The following settings can be enabled / disabled by clicking on their respective checkboxes:

- **Automatically read card contents after scanning:** If enabled, the system activates the OCR process to read the card contents after scanning. If disabled, OCR is not activated and only the scanned card image is displayed.
- **Automatically correct for upside-down cards:** If enabled, the system automatically flips the image to the correct orientation even if it was scanned in upside down.
- **Automatically update data in Lastname field:** If enabled, BizCardReader will automatically update the Lastname field with data from the Name field whenever the Name field is changed.
- **Prompt before overwriting database:** If enabled, when the user wishes to save the database, BizCardReader prompts before overwriting the current contents of the database.
- **Enable balloon help:** If enabled, the system will pop up the balloon help when the cursor is placed over an icon.
- **Use uppercase for field data:** If enabled, the system changes the card contents to uppercase when writing into the data fields.

To activate/de-activate an option, simply click on the corresponding checkbox to add/remove the check. To confirm the settings, click **OK**.

The **Maximum records per database** parameter allows you to set the maximum number of records that can be accommodated in a single database.

# Scanner Settings

---

To view and change scanner settings, select the **Settings** menu item. Then select the **Scanner** option. The Scanner Settings dialog box appears. The following options are available.

## Image Format

This specifies the format to save the scanned card images. The recommended format is JPEG Medium Compress(ion).

## Scan Resolution

The recommended setting is 300 or 400 dpi

## Scan Brightness

The recommended setting is NORMAL, and typically should not be changed. If you find that the scanned cards are consistently scanned in too dark, you can select the Lighter or Lightest options. Similarly, select Darker or Darkest if the cards are scanned in too light.

## Image Type

Select the image type to store the images. The recommended image type is 24 bit color.

### **Double Sided Card Images**

When scanning double sided cards, you can tile the front and back images of the card either vertically, one above the other, or horizontally, one beside the other.

### **Automatically start scanning when document is on the card scanner**

Check this option if you want the system to automatically start scanning when a card, photo, or other document is placed on the scanner

### **Select...**

Click this button to select a scanner. A Select Scanner dialog box appears showing the list of available scanners. Select a scanner from the list and click the OK button.

### **Calibrate...**

Calibration should be performed the first time the scanner is used, and periodically, once every 4 - 6 months. Click on this button to begin calibration.

## **Getting Started**

---

### **Scanning Business Cards**

The BizCardReader scanner is a portable high-resolution card scanner. After installing the scanner and application software, you are ready to begin scanning.

1. Startup BizCardReader.
2. Check that the Auto-Start scan feature is enabled (see Scanner Settings for details).
3. Place the card or photo face down on the scanner. Gently slide the card forward into the scanning slot.
4. The scanner will automatically start scanning and the card will be pulled through the scanner.
5. Insert the next card when prompted, until all cards or photos have been scanned.

When you have finished scanning the cards, a **Progress Window** showing the status is displayed. After the image files are processed, the last processed record is displayed in the address book.

If the orientation of any card is not upright, the Auto Orientation feature will usually detect the correct orientation and rotate the image to the upright position. In the event that this feature does not correctly detect the orientation, you do not need to rescan the cards; you can use the Rotate facility in the main menu to correct the orientation.

The system will automatically place the card information into their respective record fields. Sometimes, there is information on a card that the system cannot classify. This is placed into the **Notes** field.

### **Scanning double-sided cards**

To scan a double sided card, place a check in the "Double Side" option in the main menu display. Then place the first side of the card on the scanner to begin scanning. The system will prompt you to insert the second side when ready.

You can control the way the front and back of the cards are tiled from the options in Scanner Settings.

## Attaching Images

BizCardReader allows you to attach multiple images (up to 8) to a single record. This feature is useful for storing additional cards or photographs associated with a contact record.

To attach images to a record:

1. Select and display the record.
2. Click the Attach Image icon, or select Image... Attach Image option.
3. Specify the scanning options in the Attach Image dialog box.
4. Place the image to be scanned onto the scanner and then click OK.

# Transferring data

---

BizCardReader has extensive features which enable you to easily transfer all the text information from its database to applications such as spreadsheets, contact managers and handheld devices.

## Transfer data to Microsoft Outlook

The simplest way to transfer data to Microsoft Outlook is to use the built-in synchronization feature. To synchronize data with Outlook:

1. Outlook should be installed on your system.
2. Start up BizCardReader and click on File... Sync Data... Setup.
3. Select Outlook as the destination application and click OK.
4. In the Transfer/Synchronization dialog box, click on the Outlook tab.
5. Select the destination folder.
6. Specify the records to transfer – all or current only.
7. Specify the synchronization options (refer to the online help in BizCardReader for more information) by clicking on the appropriate tabs. Then click OK.
8. To start synchronization, select File... Synchronize data... Go, or click on the Synchronize data icon.

## Transfer data to Lotus Notes

The simplest way to transfer data to Lotus Notes (R5 or higher) is to use the built-in synchronization feature. To synchronize data with Lotus Notes:

1. Lotus Notes should be installed on your system.
2. Close the Lotus Notes application, and then start up BizCardReader and click on File... Sync Data... Setup.
3. Select Lotus Notes as the destination application and click OK.
4. In the Synchronization setup dialog box, click on the Lotus Notes tab.
5. Type in the full path name to the Lotus Notes application executable file (notes.exe). For example, if you installed Lotus Notes to your C drive using the standard defaults, the full path name will normally be "C:\Lotus\Notes\notes.exe."
6. Specify the address book for storing the contact information. Normally, this will be Lotus Notes database file "C:\Lotus\Notes\Data\names.nsf."
7. Specify the records to transfer – all or current only.
8. Specify the synchronization options (refer to the online help in BizCardReader for more information) by clicking on the appropriate tabs. Then click OK.
9. To start synchronization, select File... Synchronize data... Go, or click on the Synchronize data icon.

## Transfer data to Palm Pilot

You can transfer the data in BizCardReader to Palm Pilot using the Palm Pilot HotSync feature. The following describes the procedure for setting up HotSync to work with the BizCardReader database.

### A. Set up an Automatic Export file for HotSync

1. Start up BizCardReader and open the card database (e.g. MyBCRdata) which you want to HotSync to the Palm Pilot device.
2. Click on the File menu and select Auto Export.
3. In the Automatic Export dialog box, select Palm Pilot.

4. Note the name of the automatic export file for the database, shown in the lower display box. This file will have the “.csv” extension (e.g. MyBCRdata.csv).
5. Click OK and the automatic export file will be created.

**B. Set up the HotSync Link to the Automatic Export file.**

1. Start up the HotSync manager by selecting it in the Start menu under Programs...Palm Desktop. The HotSync icon should appear at the bottom of the screen on the status bar.
2. Click on the HotSync icon and select File Link.
3. In the File Link dialog box, select Create a new link and press Next.
4. In the Create a new link dialog box, select Address book as the Application name.
5. Click on the Browse button and locate the BizCardReader automatic export file “MyBCRdata.csv” mentioned above. Highlight the file in the Select file dialog box and click Open to select it.
6. Specify a category name for the card data (e.g. "Cards"), and click Next.
7. In the Specify Import Fields dialog box, the default field mapping should be as follows:

<u>Palm Fields</u>	<u>Data in “MyBCRdata.csv”</u>
Last Name	LAST NAME
First Name	FIRST NAME
Title	TITLE
Company	COMPANY
Work	PHONE
Home	USER1
Fax	FAX
Other	MOBILE
Email	EMAIL
Address	FULL ADDRESS
City	CITY
State	STATE
Zip	CODE
Country	COUNTRY
Custom 1	WEB
Custom 2	USER2
Custom 3	USER3
Custom 4	USER4
Note	NOTES
Private	EMPTY

**Notes**

- a. All boxes to the left of the Palm Fields should be checked.
  - b. The “EMPTY” field means that there is no data in the field.
  - c. You may alter the default mapping shown above by dragging the Palm fields to the desired locations.
8. Select Windows (ANSI) for the Source file character set and click OK to confirm the mapping, then click Done to confirm the link settings.

**C. Set the Address Book HotSync Action to “Synchronize”**

1. Click on the HotSync icon at the bottom of the screen and select Custom.
2. Select the Address Book conduit and click on Change.
3. In the HotSync options, select “Synchronize the files” and click OK, and then click Done.

**Using the Hot Sync feature**

Whenever you scan in new cards into the BizCardReader database, simply

- a. Save the database, then

- b. Press HotSync on the Palm device to transfer/synchronize the data

## **Transferring data to other applications**

You can use the **Automatic Export** or the **Standard Import/Export** features to transfer the card database to other applications. For more information, refer to the online help or see the section **Exporting a Database**.

# The Main Window

When you start the BizCardReader program, it displays the main window which contains the address book, icons and the main menu bar (at the top of the screen). This window contains most of the functions you will use for your card-scanning, photo scanning and card-retrieval tasks.

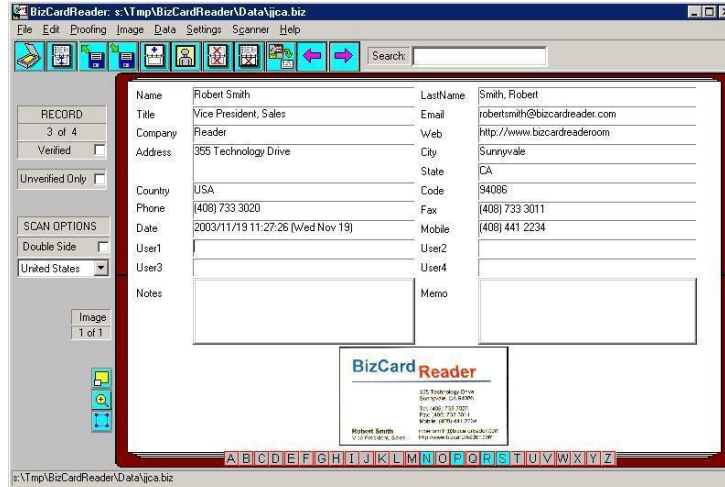

## Verified

If this box is checked, it indicates that you have verified the currently displayed card information.

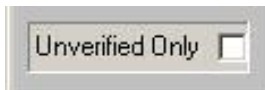

## Show Unverified Only

If this box is checked, only "unverified" records will be displayed. It allows you to quickly find all records which have not been marked as verified. Click on this box to toggle the check mark.



## Search

To search for a specific record, click in the Search input box with the left mouse. The list of available records appears in the window in tabular format. Enter the search string to find a record.



## Country of Origin

Click on the down arrow to select the country of origin of the business card. Correct country selection ensures better accuracy and performance by the system

when it reads and detects field entries such as Address, City, State and Code.

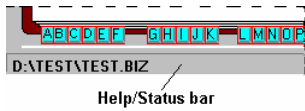

The **Help/Status bar** on the bottom of the display gives a brief description of the icon at the mouse pointer.



#### **Click to Drag cursor**

When you see the cursor message "Click to Drag", it means that you can move the indicated field contents by clicking on the mouse button and (without releasing the button) dragging the cursor to the destination field.

#### **Auto Indexing**



The letters below the address book indexes the records according to the selected sort field. Position the mouse pointer on any of the letter tabs and press the left mouse button. The first record in the database that begins with that letter will be displayed.

# Control Menu and Image Icons

---

## Control Menu Icons



**Scan**  
Start scan.  
Note: You do not need to use this button if the Auto-Scan feature is activated.



**Display Mode**  
Switch between 3 display modes.



**Save Database**  
Save the current database.



**Open Database**  
Retrieve a saved database.



**New Record**  
Create a new record by keying in data manually.



**Delete Record**  
Delete the current record and its associated card image(s).



**Delete Image**  
Delete the card image of the current record



**Attach Image**  
Attach image/photo to current record.



**Synchronize Data**  
Synchronize data with other applications.



**Next Record**  
View next record



**Previous Record**  
View previous record.

## Control Menu Icons



**Expand Image**  
Maximize the card image.



**Zoom Mode**  
Zoom in/out of the image  
(use *left/right* mouse buttons).



**Draw Zone**  
Mark a zone in the card image. The zone contents can then be dragged and placed into any record field.

# Viewing Cards

---

## Display Mode

The address book of BizCardReader is displayed in three modes. Click on the Display Mode icon to view the different modes.

You can also change the display mode by selecting Change Display under the Data menu, or by pressing F8

## Notes Field

The Notes field contains miscellaneous information extracted from the card image.

## Viewing Records

To move from one record to another use the Next and Previous icons. To move to the first or last record, select **Edit** from the main menu and choose **Go Top** or **Go Bottom** respectively. If the record number of the desired card is known, select **Goto** from **Edit** menu and input this number.

### Viewing Records in Tabular Format

To view the card database in column format, simply point the mouse within the **Search** input box and click once on the left mouse button. The records will be displayed in tabular form in the View screen. To quit the View screen, press the **Esc** key or highlight a record and press the **Return** key.

# Verifying Card Information

---

BizCardReader has a powerful proofing tool called the Card Verifier that enables you to easily proofread information in the scanned database. The verifier highlights the portion of the card image where the field information is extracted. It works in 3 modes: Normal, Cursor or Off. A tick beside a mode indicates the current mode. Choose the mode by selecting the **Proofing** option from the main menu. Choose a mode by clicking on it to select it.

**Normal Mode** - The Verifier highlights the image section when you double click on the text data in a field.

**Cursor Mode** - The Verifier automatically highlights the image section in any field where the cursor is placed.

**Off Mode** - Disables the Verifier.

### Setting Zoom Percentage

When using the Card Verifier, the line in the card image corresponding to the current highlighted word in a record field is displayed at the selected zoom magnification. The default is **Zoom 100%**. To see the highlighted line in the card image displayed at a lesser magnification, choose a smaller zoom percentage in the Proofing Menu.

## Zooming in & out of the image

To zoom in closer to any portion of the displayed image, simply click on the **Zoom** icon and then point and click on the image. To zoom out on the image, place the pointer on the image and click once on the right mouse button.

## Shifting the image Window

In **Zoom** mode, you can shift the area of the card image displayed to any desired position. To do this, place the pointer in the image window, click and hold down the left mouse button. Then move the pointer to the new position and release the mouse button.

## Rotating Scanned Image

If the scanned image of the business card or photo is not in the upright position, use the options in the Image Menu to manipulate the image. You can rotate it Right 90, Left 90 or Upsidedown 180.

## Read Card Contents

Selecting this option from the Image menu causes the system to read (OCR) the image of the currently displayed card.

## Searching and Sorting

---

### Searching for a card

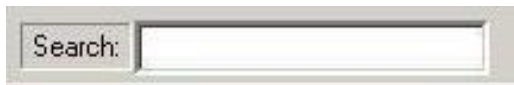

To search for a card, simply enter the search string in the **Search** input box. The default search fields are the Name and Company fields. You can search for data in any field by using the Search By... option in the Data menu.

By default, BizCardReader searches the database for cards that contain all the keywords in the search string. The search is not case-sensitive: BizCardReader will find a record with 'IBM' in a specified field regardless of the search string being 'ibm', 'Ibm', or 'ibM'. The search results are shown in a tabular form on the View screen.

To view a specific record in the View screen, simply double-click on the desired record. Alternatively, use **PageUp** or **PageDown** keys to scroll up or down the list. Press **Enter** to view the currently highlighted record in the table. Press **ESC** to exit the search display.

### Sorting

You can sort data on any field by using the **Sort By...** option under the **Data** menu.

# Editing Records

---

You can edit any of the record fields in BizCardReader just like you would in a normal word-processor.

## Editing Text

To **insert** text, click on any of the record fields and type in the information you want to add.

To **copy** text, simply highlight the text and click on Edit menu, copy option (Ctrl-C).

To **paste** text, position the cursor at the insertion point. Select Edit menu, paste option (Ctrl-V).

To **move** text, simply highlight the text and click on Edit menu, cut option (Ctrl-X). Then paste the information to the destination field.

To **delete text**, simply highlight the text and use the delete or backspace key.

To **delete a card image**, simply view the selected card and click the Delete Image icon from the menu box in the main window. *Images deleted cannot be recovered.*

## Drag & Drop

The **drag-and-drop** feature is a quick and intuitive way to edit information in the record fields.

1. Highlight the text you want to move. (or point to the field name if you are moving all information in the record field)
2. Drag the highlighted text by clicking and holding down the left mouse button.
3. Move to the destination field and release the mouse button.

### Drop Text from Image to Data Field

BizCardReader allows you to mark a reading zone on a displayed image and drag it directly into a data field.

1. Click on the Draw Zone icon and box a zone in the image for reading.
2. Point within the boxed region, click and hold down the left mouse button, and drag the "finger" cursor to a destination field.
3. Release the mouse button and the data will be read and placed into the destination field.

# Managing Databases

---

## Database Files and Image Files

All **text** information for a given database is stored in a single database file with the file extension "**.biz**". Additional miscellaneous information for the database is stored in the file with the extension "**.dat**". The images associated with the database are stored in the same directory as separate image files (with the extension ".tif", ".bmp", ".pcx" or ".jpg"). The name of each image file is prefixed with the name of the database file.

For example, if you have a database called MYDAT, then all image files associated with MYDAT have the following form: MYDAT00001.jpg, MYDAT00002.jpg, MYDAT00003.jpg.

## Opening A Database

1. Select Open from the File Menu or click the Open Database icon. The Open dialog box will appear.
2. Select a database to open and click OK. The database will be opened and the first record is displayed. BizCardReader permits only one opened database at any time.

## Saving A Database

When a database is first created, it is given the name **Untitled**. To save the current database:

1. Select Save... from the File Menu or click on the Save Database icon.
2. Type a name for the database and select the directory to save it to and click OK.

## Copying A Database

When you want to duplicate the current database for reason such as to backup the database, simply follow these steps:

1. Select Save As... from the File Menu.
2. Enter the file name and select the drive and folder you want this database to be saved under.
3. If you want to include the images in the saving process, click on the Include Images checkbox.

## Merging Databases

BizCardReader has the capability to merge databases. The current database can be expanded by importing records from another database.

Before merging databases, make sure that the Maximum Records value in the System Setting is set to a number greater than or equal to the sum of the records in the two databases to be merged. To merge two databases, follow these steps:

1. Click on the Open Database icon to open a database to which you want to add the additional records
2. From the File Menu, Select Merge database...
3. In the File Name box, enter the drive and the file name of the database you want to merge with the currently opened database. Click **OK**.
4. In the Merge database dialog box, check the Include Image(s) box if you want to include the image(s) during the merging process.
5. Select the desired radio button to specify how the system should handle duplicate records.
6. Click **OK** to start the merging process.

## Deleting a Database

You can delete a database if you no longer want to keep it in the system.

1. Select Delete from the File Menu in the main window. The Delete Database dialog box appears.
2. Select the name of the database that you wish to delete from the list box.

3. Click OK and the database will be deleted from the hard disk. All Database data and images will be deleted.

## Copy Field Contents

Copy Field Contents allows you to copy or move information from one field to another for all records in the database.

1. Select Copy Field Contents... from the Edit menu
2. Select the Source Field and the Target Field.
3. Check to Append or Overwrite information in the Target Field.
4. Check the Delete contents in Source Field after operation box if you no longer need the information in the Source Field after transferring the data.

## Updating a Database

When new records are added or the Name fields of existing records are edited, the database may not remain in the correct sorted order. The AutoIndex keys may also become dimmed. In this case, use the Update option in the Data Menu to re-sort the database.

## Exporting a Database

---

### Export Methods

BizCardReader provides several export features which enable you to easily transfer all the text information from its database to applications such as spreadsheets, contact managers and handheld devices.

- Automatic Export - Transfers all the information in the database to a target application, automatically, whenever you update the database.
- Standard Export - Transfers all or selected portions of the database, and creates new customized export formats.
- Print to File – Writes out database information to a text file or a Dbase (DBF) file.

### Automatic Export

The Automatic Export feature allows you to transfer all the text information in the database to an export file in a format that is compatible with the selected target application. Each time the database is edited and the contents saved, the export file is automatically updated. This frees you from the tedium of having to manually export the database whenever you scan new cards into the database or update the database contents.

To set up the automatic export feature, do the following.

1. Startup BizCardReader. Select Open from the File Menu to open a database containing the information you want to export.
2. Select Import/Export from the File Menu and then select Auto Export from the sub-menu. The Automatic Export dialog box appears.
3. Select the (target) application format by clicking on the down arrow of the Application list box. If the application is not listed, you should select and use one of the Standard Application formats.
4. After you have selected the compatible application format, the lower edit box will display the name of the export file to which database contents will be saved. The name of the export file will be the name of the database followed by the “.csv” or “.txt” extension.
5. Note the name of the export file. Then click OK to confirm your selection or Cancel to quit.

**Note:** After you have selected the target application and clicked OK, the system will automatically save or update the database contents to the export file whenever the current database is edited and saved. When you close the current database and open another database, the Automatic Export feature remains in effect and will save the newly opened database to a new export file as specified in step (4) above.

To disable the automatic export feature, select “NONE” in the Application list box of the Automatic Export dialog box.

To read in the database into the target application, startup the application and use its import utility to read in the export file obtained in step (4).

## Printing

---

### Printing Labels

BizCardReader can generate mailing labels for all or selected contacts in the database. To print labels:

1. Select Print from the File Menu, and then select Print Label from the sub-menu. The Print Label dialog box appears.
2. Select the Print Range and Print Label options.
3. Click the Labels button to select the types of label you want to print. The Select Label dialog box appears.
4. Listed in the Labels list box are standard label types. To choose one of them, click on the desired label type and then click OK to return to the Print Label dialog box. If the desired label type is not listed, you can create a new label format by clicking on the New button.
5. Click the Fields button to select the fields that you wish to print. Click OK when done.
6. In the Print Label dialog box, select your desired font type by clicking on Fonts button. Click on Setup button to setup the printer.
7. Click Preview from the Print Label dialog box to view the layout of the labels in a page.
8. If the layout is OK, click on Print button to start printing.

### Label Layout

The following gives an example of defining the label layout.

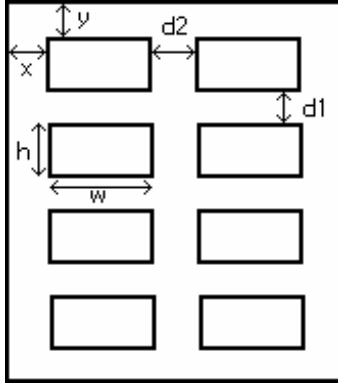

Number of Label Rows: **4**  
 Number of Label Columns: **2**  
**w** - Label Width  
**h** - Label Height  
**d1** - Vertical label distance  
**d2** - Horizontal label distance  
**x** - Top left label from left edge  
**y** - Top left label from top edge

## Printing a Report

BizCardReader allows you to print out a listing of the database in a table format. To print the database:

1. Select Print from the File Menu, and then select Print Label from the sub-menu. The Print Table dialog box will appear.
2. Set the range to Print.
3. Under Column Spacing, select Space Equally option if you want equal spacing between the fields. It is recommended that you use System Default which is the spacing provided by BizCardReader.
4. Set the options under Print Options. The "Number Pages" option generates page numbers for your output. The "Draw Table Outline" option allows you to print information with lines to show columns.
5. Click the Fields button to select the fields that you wish to print. The Select Output Field dialog box appears. Click **OK** to return to the Print Table dialog box.
6. Click the Font button to set the font type.

Click Preview to view the layout of the database. If the layout is OK, click on **Print** button to proceed on printing. Otherwise click **Close** to return to Print Table dialog box.

## Print to File

The Print-to-File option allows you to write database information to a text file or a Dbase (DBF) file. Writing to a text file is useful if you need to transfer the database information to a word processor for manual editing and formatting prior to printing. Writing to a DBF file allows you to transfer the database information to another application that is capable of handling DBF files.

1. Select Print from the File Menu, and then select Print to File from the sub-menu. The Print To File dialog box appears.
2. In the Print Range, select to save Current Record, Selected Records, Search Result or Full Database.
3. In the Format pull down menu, click the down arrow and select the application you want to print to.
4. Specify the filename and directory to save the output file and click **OK**.

# Scanner Maintenance

---

The scanner requires no maintenance except for occasional cleaning. Dirt and other foreign particles from scanned cards and photographs may accumulate on the scanning glass and roller after an extended period of scanning. If there are noticeable dark lines in the scanned images, the scanner may need cleaning.

## DuplexScan 1200 Cleaning Procedure

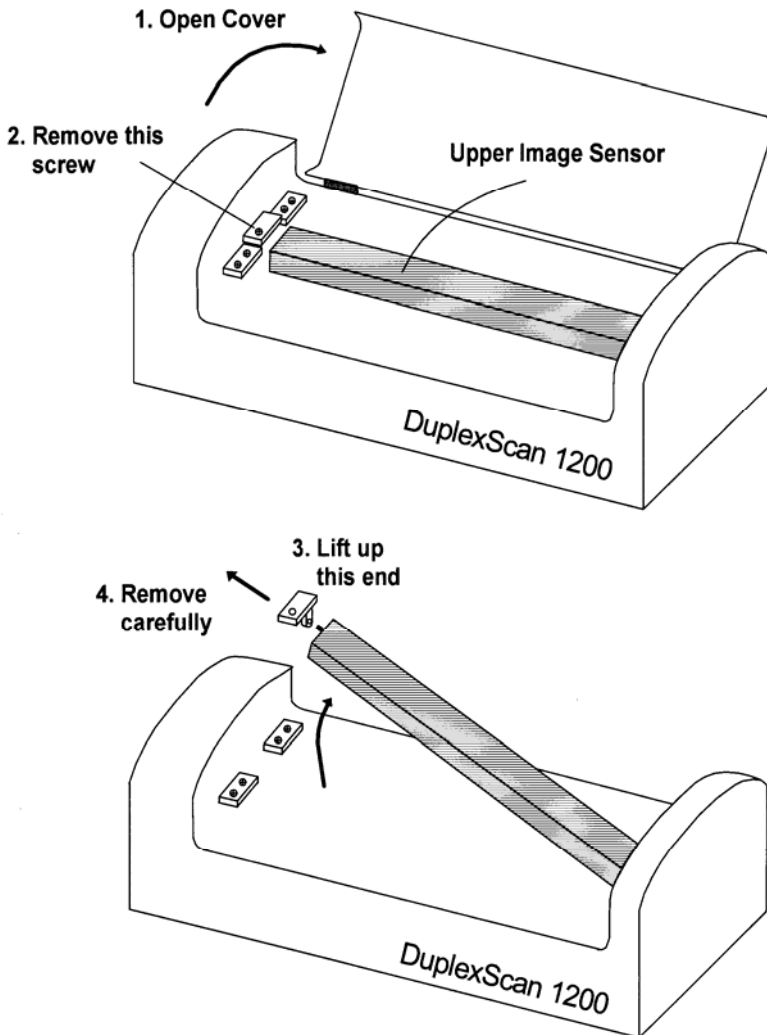

1. Lift up the top cover of the scanner.
2. Remove the SINGLE screw as shown. Use a small Philips head screwdriver. DO NOT remove any other screw.
3. Carefully lift up the left end of the upper imaging sensor.
4. Slide off the end retainer and remove the sensor from the right end pivot hole. DO NOT detach the white ribbon cable from the sensor.
5. Turn the upper sensor so that the glass plate faces up. Then rest the sensor on the scanner.

6. Wipe away dirt or other particles from the upper and lower glass plates and rubber rollers with a dry cotton cloth. Use a small amount of rubbing alcohol if needed.
7. Carefully re-assemble the scanner. **Do not use excessive force when tightening the screws.**

### BizCardReader 900C Cleaning Procedure

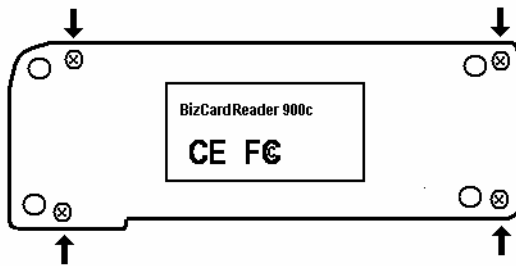

*BizCardReader 900c (Bottom View)*

8. Turn the scanner over so that the bottom side faces up.
9. Remove the 4 screws located on the bottom of the scanner as shown. Use a small flat head screwdriver. **DO NOT** remove any other screw.
10. Turn the scanner upright and carefully lift off top cover.
11. Wipe away dirt or other particles from the glass plate and rubber roller with a dry cotton cloth. Use a small amount of rubbing alcohol if needed.
12. Carefully re-assemble the top cover and screws. **Do not use excessive force when tightening the screws.**

### BizCardReader 600C Cleaning Procedure

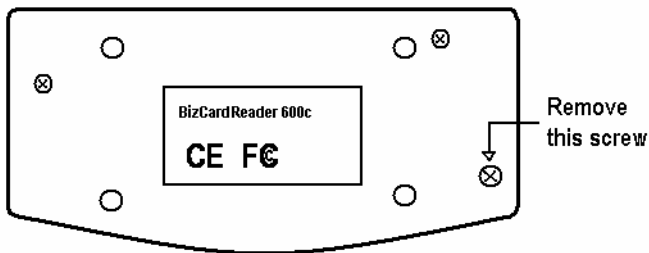

*BizCardReader 600c (Bottom view)*

- a. Turn the scanner over so that the bottom side faces up.
- b. Remove the screw located on the bottom-right of the scanner as shown. Use a small flat head screwdriver. **DO NOT** remove any other screw.

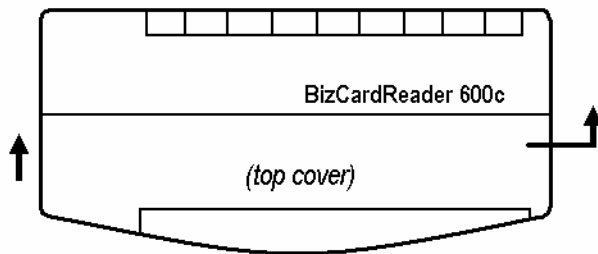

- c. Turn the scanner upright and slide the top cover slightly to the right and lift up carefully.
- d. Remove the black rubber roller by lifting it up from the roller slots.
- e. Wipe away dirt or other particles from the glass plate and rubber roller with a dry cotton cloth. Use a small amount of rubbing alcohol if needed.
- f. Replace the roller and carefully re-assemble the cover and screw. **Do not use excessive force when tightening the screw.**

#### BizCardReader 300G Cleaning Procedure

To clean the BizCardReader 300G card scanner, follow the same cleaning procedure (a-f) for BizCardReader 600C. The housing screw is similarly located on the bottom left of the scanner; remove and replace the top housing in the same manner as for the model 600C scanner.

# Scanner Warranty and Notices

---

## Limited Warranty

CardReader, Inc. ("Manufacturer") grants a limited 90 day warranty for the BizCardReader 300G/600C/900C/1200DX card scanner ("Scanner"), effective from the date of purchase. The Scanner is only covered by the terms of the warranty if it has been handled properly in normal use and used only for the purposes for which it has been designed.

If the Scanner is found to be defective in any way during its warranty period, Manufacturer will either repair or replace the defective Scanner; the course of action (repair or replacement) to be taken being determined by the Manufacturer alone. This warranty does not cover damage to the Scanner, resulting from accident, disasters, misuse, abuse, or any unauthorized modification of the Scanner. Limited warranty service may be obtained by delivering the defective Scanner to the Manufacturer within the effective warranty period, together with its original proof-of-purchase.

Each warranty is effective only for the duration of its warranty period, and no warranty will apply after the end of its warranty period. After the expiration of the warranty period, the cost of repairing and/or replacing Scanner will be borne by the user.

THE ABOVE WARRANTIES ARE EXCLUSIVE AND IN LIEU OF ALL OTHER WARRANTIES, EXPRESSED OR IMPLIED, INCLUDING BUT NOT LIMITED TO THE IMPLIED WARRANTIES OF MERCHANTABILITY, FITNESS FOR A PARTICULAR PURPOSE AND NONINFRINGEMENT. NO ORAL OR WRITTEN INFORMATION OR ADVICE GIVEN BY MANUFACTURER, OR ITS EMPLOYEES, DISTRIBUTORS, AGENTS, OR DEALERS SHALL INCREASE THE SCOPE OF THE ABOVE WARRANTIES OR CREATE ANY NEW WARRANTIES.

THIS WARRANTY GIVES YOU SPECIFIC LEGAL RIGHTS, AND YOU MAY HAVE OTHER LEGAL RIGHTS THAT MAY VARY FROM STATE TO STATE.

### LIMITATION OF LIABILITY

MANUFACTURER SHALL NOT BE LIABLE FOR ANY DAMAGES WHATSOEVER (INCLUDING, WITHOUT LIMITATION TO, DAMAGES FOR LOSS OF PROFITS, BUSINESS INTERRUPTION, LOSS OF INFORMATION, OR OTHER PECUNIARY LOSS) ARISING OUT OF THE USE OR INABILITY TO USE THE SCANNER. IN NO EVENT SHALL MANUFACTURER'S LIABILITY FOR DAMAGES RELATED TO THE INSTALLATION OR USE OF THE SCANNER EXCEED THE AMOUNT YOU PAID FOR THE SCANNER.

SOME JURISDICTIONS DO NOT ALLOW EXCLUDING OR LIMITING IMPLIED WARRANTIES OR LIMITING LIABILITY FOR INCIDENTAL OR CONSEQUENTIAL DAMAGES, AND SOME JURISDICTIONS HAVE SPECIAL STATUTORY CONSUMER PROVISIONS WHICH MAY SUPERSEDE THIS LIMITATION. AS A RESULT, THIS LIMITATION OF LIABILITY MAY NOT APPLY TO YOU IF PROHIBITED BY THE LAWS OF YOUR JURISDICTION.

## FCC Statement

This equipment has been tested and found to comply with the limits for a Class B digital device, pursuant to Part 15 of the FCC Rules. These limits are designed to provide reasonable protection against harmful interference in a residential installation. This equipment generates, uses and can radiate radio frequency energy and, if not installed and used in accordance with the instructions, may cause harmful interference to radio communications. However, there is no guarantee that interference will not occur in any particular installation.

If this equipment does cause harmful interference to radio or even television reception, which can be determined by turning the equipment off and on, the user is encouraged to try to correct the interference by one or more of the following measures:

- Reorient the receiving antenna.
- Increase the separation between the equipment and the receiver.
- Connect the scanning and computer equipment into an outlet on a circuit different from that which the receiver is connected.
- Consult the dealer or an experienced radio / TV technician for help.

## Declaration of Conformity

DECLARATION OF CONFORMITY

According to 47CFR, Part 2 and 15 for:  
Class B Personal Computers and Peripherals; and/or  
CPU Boards and Power Supplies used with Class B  
Personal Computers:

We: CardReader, Inc.  
Located at: 1411 Ramon Dr.  
Sunnyvale, CA 94087  
Telephone: (408) 733 2233

Declare under sole responsibility that the product identified herein, complied with 47CFR Part 2 and 15 of the FCC rules as a Class B digital device. Each product marketed is identical to the representative unit tested and found to be compliant with the standards. Records maintained continue to reflect the equipment being produced can be expected to be within the variation accepted, due to quantity production and testing on a statistical basis as required by 47CFR 2.909. Operation is subject to the following two conditions: (1) this device may not cause harmful interference, and (2) this device must accept any interference received, including interference that may cause undesired operation.

Trade Name: BizCardReader / DuplexScan 1200  
Type of Product: Card Scanner  
Models: USB201 / USB203 / BCR300 / BCR900 / BizCardReader 1200DX